

# TB 9-6625-2330-35

CHANGE 3

DEPARTMENT OF THE ARMY TECHNICAL BULLETIN

## CALIBRATION PROCEDURE FOR SIGNAL GENERATOR SG-1207A/U (WAYNE-KERR, MODEL PSG2400L)

Headquarters, Department of the Army, Washington, DC  
16 August 2006

*Distribution Statement A: Approved for public release; distribution is unlimited.*

TB 9-6625-2330-35, 15 April 2004, is changed as follows:

1. Remove old pages and insert new pages as indicated below. New or changed material is indicated by a vertical bar in the margin of the page.

**Remove Pages**  
3 and 4

**Insert Pages**  
3 and 4

2. File this change sheet in front of the publication for reference purposes.

**By Order of the Secretary of the Army:**

Official:

  
JOYCE E. MORROW  
Administrative Assistant to the  
Secretary of the Army

0617101

**PETER J. SCHOOMAKER**  
General, United States Army  
Chief of Staff

Distribution:

To be distributed in accordance with IDN 344734 requirements for TB 9-6625-2330-35.



# TB 9-6625-2330-35

CHANGE 2

DEPARTMENT OF THE ARMY TECHNICAL BULLETIN

## CALIBRATION PROCEDURE FOR SIGNAL GENERATOR SG-1207A/U (WAYNE-KERR, MODEL PSG2400L)

Headquarters, Department of the Army, Washington, DC  
6 October 2004

*Distribution Statement A: Approved for public release; distribution is unlimited.*

TB 9-6625-2330-35, 15 April 2004, is changed as follows:

1. Remove old pages and insert new pages as indicated below. New or changed material is indicated by a vertical bar in the margin of the page.

**Remove Pages**

1 and 2  
9 and 10  
11 and 12  
13 and 14

**Insert Pages**

1 and 2  
9 and 10  
11 and 12  
13 and 14

2. File this change sheet in front of the publication for reference purposes.

**By Order of the Secretary of the Army:**

Official:

**PETER J. SCHOOMAKER**  
*General, United States Army*  
*Chief of Staff*

  
**JOEL B. HUDSON**  
*Administrative Assistant to the*  
*Secretary of the Army*

0422215

Distribution:

To be distributed in accordance with IDN 344734 requirements for TB 9-6625-2330-35.



# TB 9-6625-2330-35

CHANGE 1

DEPARTMENT OF THE ARMY TECHNICAL BULLETIN

## CALIBRATION PROCEDURE FOR SIGNAL GENERATOR SG-1207A/U (WAYNE-KERR, MODEL PSG2400L)

Headquarters, Department of the Army, Washington, DC  
5 August 2004

*Distribution Statement A: Approved for public release; distribution is unlimited.*

TB 9-6625-2330-35, 15 April 2004, is changed as follows:

1. Remove old pages and insert new pages as indicated below. New or changed material is indicated by a vertical bar in the margin of the page.

### Remove Pages

5 and 6  
13 and 14  
15 and 16  
17 and 18

### Insert Pages

5 and 6  
13 and 14  
15 and 16  
17 and 18

2. File this change sheet in front of the publication for reference purposes.

**By Order of the Secretary of the Army:**

Official:

**PETER J. SCHOOMAKER**  
*General, United States Army*  
*Chief of Staff*

  
**JOEL B. HUDSON**

*Administrative Assistant to the*  
*Secretary of the Army*

0415903

Distribution:

To be distributed in accordance with IDN 344734 requirements for TB 9-6625-2330-35.



# \*TB 9-6625-2330-35

DEPARTMENT OF THE ARMY TECHNICAL BULLETIN

## CALIBRATION PROCEDURE FOR SIGNAL GENERATOR SG-1207A/U (WAYNE-KERR, MODEL PSG2400L)

Headquarters, Department of the Army, Washington, DC  
15 April 2004

*Distribution Statement A: Approved for public release; distribution is unlimited.*

### REPORTING OF ERRORS AND RECOMMENDING IMPROVEMENTS

You can improve this manual. If you find any mistakes or if you know of a way to improve these procedures, please let us know. Mail your letter or DA Form 2028 (Recommended Changes to Publications and Blank Forms) directly to: Commander, US Army Aviation and Missile Command, AMSAM-MMC-MA-NP, Redstone Arsenal, AL 35898-5000. A reply will be furnished to you. You may also provide DA Form 2028 information to AMCOM via e-mail, fax, or the World Wide Web. Our fax number is DSN 788-6546 or Commercial 256-842-6546. Our e-mail address is [2028@redstone.army.mil](mailto:2028@redstone.army.mil). Instructions for sending an electronic 2028 may be found at the back of this manual. For the World Wide Web, use <https://amcom2028.redstone.army.mil>.

SECTION		Paragraph	Page
I.	IDENTIFICATION AND DESCRIPTION		
	Test instrument identification .....	1	2
	Forms, records, and reports .....	2	2
	Calibration description .....	3	2
II.	EQUIPMENT REQUIREMENTS		
	Equipment required .....	4	4
	Accessories required .....	5	4
III.	CALIBRATION PROCESS		
	Preliminary instructions .....	6	5
	Equipment setup .....	7	6
	Line stability .....	8	6
	Frequency accuracy .....	9	7
	RF output .....	10	8
	Output level flatness .....	11	11
	Attenuation .....	12	12
	Spectral purity .....	13	14
	Pulse modulation .....	14	16
	Internal oscillator .....	15	19

\*This technical bulletin supersedes TB 9-6225-2330-35, dated 18 March 2002.

	Paragraph	Page
Amplitude Modulation.....	16	20
Frequency modulation.....	17	22
Phase modulation .....	18	24
Final procedure .....	19	26

**SECTION I  
IDENTIFICATION AND DESCRIPTION**

**1. Test Instrument Identification.** This bulletin provides instructions for the calibration of Signal Generator, SG-1207A/U (Wayne-Kerr, Model PSG2400L). TM 43-6625-911-14&P was used as the prime data source in compiling these instructions. The equipment being calibrated will be referred to as the TI (test instrument) throughout this bulletin.

**a. Model Variations.** There are at least two different SG-1207A/U versions fielded. While there are no operational differences between versions, there are internal differences that are maintenance significant. Therefore, the only adjustment included in this procedure is for the 10 MHz Ref Adj. Additional adjustments are contained in TM 43-6625-911-14&P.

**b. Time and Technique.** The time required for this calibration is approximately 6 hours, using the dc and low frequency and microwave technique.

**2. Forms, Records, and Reports.** Forms, records, and reports required for calibration personnel at all levels are prescribed by TB 750-25.

**3. Calibration Description.** TI parameters and performance specifications which pertain to this calibration are listed in table 1.

Table 1. Calibration Description

Test instrument parameters	Performance specifications
Frequency	Range: 100 kHz to 2000 MHz Accuracy: $\pm 1$ PPM Time stability: $\pm 0.02$ PPM/24hour Line stability: $\pm 1$ PPM, 10% line change <sup>1</sup>
RF output	Range: $>15$ to $-125$ dBm <sup>2</sup> Flatness: $\pm 1.5$ dB (100 kHz to 1000 MHz) $\pm 2.5$ dB (1000 MHz to 2000 MHz) Attenuator accuracy: $\pm 1.5$ dB (100 kHz to 1000 MHz) $\pm 2.5$ dB (1000 MHz to 2000 MHz)

See footnotes at end of table.



Table 1. Calibration Description - Continued

Test instrument parameters	Performance specifications
Spectral purity	<p>Harmonics range: Accuracy:                      100 kHz to 2000 MHz &lt;+13 dBm, &lt;-25 dBc                      &lt;+3 dBm,                      &lt;-30 dBc</p> <p>Sub harmonic range: Accuracy:                      100 kHz to 1200 MHz &lt;+3 dBm, &lt;-40 dBc                      100 kHz to 2000 MHz &lt;+3 dBm, &lt;-30 dBc                      100 kHz to 2000 MHz &lt;+13 dBm, &lt;-20 dBc</p> <p>Spurious signal range: Accuracy:                      100 kHz to 2000 MHz &lt;+13 dBm, &lt;-50 dBc                      = &gt;5 kHz carrier offset</p>
Pulse modulation	<p>Pulse range: 100 kHz to 2000 MHz                      Pulse rate: 50 Hz to 10 MHz                      Pulse envelope on/off ratio: Accuracy                      (100 kHz to 2000 MHz) &gt;60 dB</p> <p>Pulse envelope rise/falltime &lt;25 nanoseconds (10% to 90%)</p>
Amplitude modulation	<p>Frequency range: 100 kHz to 2000 MHz                      Depth: 0 to 99.9% in .1% increments                      Accuracy: <math>\pm 7\%</math> of setting at 1 kHz rate                      and modulation depth of 30% to 70%                      Distortion: &lt;3%, (30% to 70% depth, 1 kHz rate)                      (3 dB bandwidth 300 Hz to 3 kHz)                      Incidental FM: &lt;200 Hz (30% at 1 kHz)                      (3 dB bandwidth 300 Hz to 3 kHz)                      Residual AM: &lt;0.1% rms, (300 Hz to 3 kHz)<sup>3</sup></p>
Frequency modulation	<p>Frequency response: 50 Hz to 100 kHz internal/external                      Deviation range: 10 Hz to 200 kHz                      Accuracy: <math>\pm 5\%</math> at 1 kHz rate                      Incidental AM: &lt; 1% (3 dB bandwidth 300 Hz to 3 kHz,                      1 kHz rate)                      Distortion: <math>\leq 2\%</math> (3 dB bandwidth 300 Hz to 3 kHz                      1 kHz rate and deviation &gt; 8 kHz)                      Residual FM: &lt;20 Hz rms, (300 Hz to 3 kHz)</p>
Phase modulation	<p>Modulation bandwidth: 100 Hz to 10 kHz                      Deviation range: 0 to 10 radians <math>\pm 10\%</math> of setting (1 kHz rate)                      Frequency response: <math>\pm 2</math> dB relative to 1 kHz rate                      across modulation bandwidth                      Distortion: &lt;2% (3 dB bandwidth 300 Hz to 3 kHz                      at 1 kHz rate and deviation &gt; 8 kHz)</p>

See footnotes at end of table.

Table 1. Calibration Description - Continued

Test instrument parameters	Performance specifications
Internal oscillator	Frequency range: .1 Hz to 500 kHz Accuracy: Same as time base Distortion: <0.2%, (@ 1 kHz and 400 Hz) Output: 1 V rms into 50 Ω nominal Accuracy: ±5%

<sup>1</sup>Line stability verified to 8.7% line change.

<sup>2</sup>Range verified to -110 dBm.

<sup>3</sup>Not verified in this procedure.

## SECTION II EQUIPMENT REQUIREMENTS

**4. Equipment Required.** Table 2 identifies the specific equipment to be used in this calibration procedure. This equipment is issued with Secondary Transfer Calibration Standards Set AN/GSM-287. Alternate items may be used by the calibrating activity. The items selected must be verified to perform satisfactorily prior to use and must bear evidence of current calibration. The equipment must meet or exceed the minimum use specifications listed in table 2. The accuracies listed in table 2 provide a four-to-one ratio between the standard and TI. Where the four-to-one ratio cannot be met, the actual accuracy of the equipment is shown in parenthesis.

**5. Accessories Required.** The accessories required for the calibration are common usage accessories, issued as indicated in paragraph 4 above, and are not listed in this calibration procedure. The following peculiar accessories are also required for this calibration: 50 Ω feedthrough termination, Hewlett-Packard Model 11048C and crystal detector, Hewlett-Packard Model 423A.

Table 2. Minimum Specifications of Equipment Required

Common name	Minimum use specifications	Manufacturer and model (part number)
AUDIO ANALYZER	Distortion capability: ≤ .05% Range: 20 Hz to 100 kHz	Boonton, Model 1121 (1121)
AUTOTRANSFORMER	Range: 105 to 125 V ac Accuracy: ±1%	General Radio, Type W10MT3AS3 (7910809) or Ridge, Model 9020A (9020A) or Ridge, Model 9020F (9020F)
FREQUENCY COUNTER	Range: 20 Hz to 2000 MHz Accuracy: ±2.5 ppm or .00025%	Fluke, Model PM6681/ 656 (PM6681/656)
FREQUENCY DIFFERENCE METER	Range: 10 MHz Resolution: 1 part in 10 <sup>10</sup>	Tracor, Model 527E

Table 2. Minimum Specifications of Equipment Required - Continued

Common name	Minimum use specifications	Manufacturer and model (part number)
MEASURING RECEIVER	Power measurement: (+13 dB to -110 dB) ±.375 dB  Flatness measurement: (100 kHz to 1000 MHz) ±.375 dB (100 kHz to 2000 MHz) ±.625 dB	Hewlett-Packard, Model 8902A w/sensors, Hewlett-Packard, Model 11722A (11722A)
MULTIMETER	Range: 50 to -15 V dc Accuracy: ±.25%	Fluke, Model 8840A/AF-05/09 (AN/GSM-64D)
OSCILLOSCOPE	Range: 50 kHz Accuracy: <25 ns risetime	(OS-303/G)
PULSE GENERATOR	Amplitude: 5 V Period: 10 ms to 20 µs Width: 5 ms to 6 µs	LeCroy, Model 9210 (9210) w/plugin-ins, LeCroy Models 9211 (9211) and 9215 (9215) (MIS-45839)
SPECTRUM ANALYZER	Range: 100 kHz to 2 GHz (13 to -90 dB) Accuracy: ±1.0 dB/10 dB step, 1.0 dB maximum	(AN/USM-677)
TIME/FREQUENCY WORKSTATION	Range: 1 MHz Accuracy: 5 parts in 10 <sup>9</sup>	Datum, Model ET6000-75 (13589305)

### SECTION III CALIBRATION PROCESS

#### 6. Preliminary Instructions

a. The instructions outlined in paragraphs 6 and 7 are preparatory to the calibration process. Personnel should become familiar with the entire bulletin before beginning the calibration.

b. Items of equipment used in this procedure are referenced within the text by common name as listed in table 2.

c. Unless otherwise specified, verify the result of each test and, whenever the test requirement is not met, take corrective action before continuing with the calibration. Adjustments required to calibrate the TI are included in this procedure. Additional maintenance information is contained in TM 43-6625-911-14&P for this TI.

d. When indications specified in paragraphs 7 through 16 are not within tolerance, perform the power supply check prior to making adjustments. After adjustments are made, repeat paragraphs 7 through 16. Do not perform power supply check if all other parameters are within tolerance.

e. Unless otherwise specified, all controls and control settings refer to the TI.

## 7. Equipment Setup

### WARNING

HIGH VOLTAGE is used or exposed during the performance of this calibration. DEATH ON CONTACT may result if personnel fail to observe safety precautions. REDUCE OUTPUT(S) to minimum after each step within the performance check where applicable.

### NOTE

Before connecting TI, the protective earth terminal of the instrument must be connected to the protective conductor of the line power cord. The line plug shall only be inserted in a socket outlet provided with a protective earth contact. The protective action must not be negated by the use of an extension cord (power cable) without a protective conductor (grounding). Grounding one conductor of a two-conductor outlet is not sufficient protection.

### NOTE

When indications specified in this procedure are not within tolerance, perform the power supply check prior to making adjustments.

- a. Connect TI to autotransformer.
- b. Connect autotransformer to a 115 V ac source and adjust autotransformer to 115 V ac.
- c. Press **POWER** pushbutton to **ON** and allow at least 30 minutes for TI to stabilize.
- d. Connect **REF IN/OUT** to frequency difference meter **SIG INPUT**.
- e. Connect a 1 **MHz** output using time/frequency workstation to frequency difference meter **REF INPUT**.
- f. Adjust **REF ADJ** (TI rear panel) for a minimum frequency difference meter indication.
- g. Verify oscillator drift is less than 2 parts in  $10^8$  in 24 hours.
- h. Disconnect frequency difference meter from TI and time/frequency workstation.

## 8. Line Stability

### a. Performance Check

- (1) Connect frequency counter input **A** to TI **RF OUTPUT**.

- (2) Set up frequency counter controls to measure frequency with 50 Ω input.
- (3) Press TI pushbuttons as listed in (a) through (e) below:
  - (a) **FUNCTION-CARR FREQ.**
  - (b) **DATA ENTRY-100 MHz.**
  - (c) **FUNCTION-CARR LEVEL.**
  - (d) **DATA ENTRY-0 dBm.**
  - (e) **FUNCTION-RF ON** to on (red light lit).
- (4) Record frequency counter indication.
- (5) Vary autotransformer to voltage level indicated in first row of table 3. Frequency counter will indicate within ±100 Hz of recorded value in (4) above.
- (6) Repeat (5) above for remaining voltage levels listed in table 3.

Table 3. Line Stability

Autotransformer voltage indications	Frequency counter indication at 100 MHz ±100 Hz
125 V ac	
120 V ac	
110 V ac	
105 V ac	

- (7) Adjust autotransformer to 115 V ac.

**b. Adjustments.** No adjustments can be made.

**9. Frequency Accuracy**

**a. Performance Check**

- (1) Connect frequency counter input **A** to **TI RF OUTPUT**.
- (2) Set up frequency counter controls to measure frequency with 50 Ω input.
- (3) Press TI pushbuttons as listed in (a) through (e) below:
  - (a) **FUNCTION-CARR FREQ.**
  - (b) **DATA ENTRY-100 kHz.**
  - (c) **FUNCTION-CARR LEVEL.**
  - (d) **DATA ENTRY- -3 dBm.**
  - (e) **FUNCTION-RF ON** to on (red light lit).
- (4) Frequency counter will indicate within limits specified in table 4.
- (5) Set TI to next frequency listed in table 4 using **TI FUNCTION-CARR FREQ** and **DATA ENTRY** keys and repeat (4) above.
- (6) Repeat (4) and (5) above for remaining frequencies listed in table 4.

Table 4. Frequency

Test instrument <b>DATA ENTRY</b> frequency	Frequency counter indications	
	Min	Max
.100 MHz	.0999999 MHz	.1000001 MHz
.500 MHz	.4999995 MHz	.5000005 MHz
1 MHz	.999999 MHz	1.000001 MHz
5 MHz	4.999995 MHz	5.000005 MHz
10 MHz	9.999990 MHz	10.000010 MHz
50 MHz	49.999950 MHz	50.0000500 MHz
100 MHz	99.999900 MHz	100.000100 MHz
500 MHz <sup>1</sup>	499.999500 MHz	500.000500 MHz
1300 MHz	1299.998700 MHz	1300.001300 MHz
2000 MHz	1999.998000 MHz	2000.002000 MHz

<sup>1</sup>Press TI **FUNCTION-RF ON** to off (red light extinguished). Disconnect cable from frequency counter input **A** and connect cable to frequency counter input **C**. Press TI **FUNCTION-RF ON** (red light lit) and verify frequency counter is within limits listed.

(7) Press TI **FUNCTION-RF ON** pushbutton to off (red light extinguished).

**b. Adjustments.** No adjustments can be made.

## 10. RF Output

### a. Performance Check

#### NOTE

If necessary, perform measuring receiver and sensor module **ZERO** and **CALIBRATE**.

- (1) Connect measuring receiver sensor module (11722A) input to TI **RF OUTPUT**.
- (2) Connect TI **REF IN/OUT** (rear panel) to measuring receiver **TIME BASE 10 MHz INPUT** (rear panel).
- (3) Press TI pushbuttons as listed in (a) through (e) below:
  - (a) **FUNCTION-CARR FREQ.**
  - (b) **DATA ENTRY-30 MHz.**
  - (c) **FUNCTION-CARR LEVEL.**
  - (d) **DATA ENTRY- 13 dBm.**
  - (e) **FUNCTION-RF ON** to on (red light lit).
- (4) Using measuring receiver and RF power measurement techniques; measuring receiver will indicate within limits specified in table 5 for TI RF power level setting.
- (5) Press TI **FUNCTION-CARR LEVEL** and **DATA ENTRY** keys to next level listed in table 5. Measuring receiver will indicate within limits specified for TI RF power level setting.

(6) Repeat (5) above for remaining levels listed in table 5.

Table 5. 30 MHz RF Output

Test instrument <b>DATA ENTRY</b> level	Measuring receiver indications (dB)	
	Min	Max
13dBm	11.5	14.5
10dBm	8.5	11.5
5dBm	3.5	6.5
0dBm	-1.5	1.5

(7) Press TI **FUNCTION-CARR LEVEL** and **DATA ENTRY** keys to set TI output level to first value listed in table 6.

(8) Using standard tuned level measurement techniques, measuring receiver will indicate within limits specified in table 6 for TI RF power level setting.

(9) Press TI **FUNCTION-CARR LEVEL** and **DATA ENTRY** keys to set TI output level to next value listed in table 6. Measuring receiver will indicate within limits specified in table 6 for TI RF power level setting.

(10) Repeat (9) above for remaining levels listed in table 6.

Table 6. 30 MHz RF Output

Test instrument <b>DATA ENTRY</b> level	Measuring receiver indications (dB)	
	Min	Max
0 dBm	-1.5	1.5
-10 dBm	-11.5	-8.5
-20 dBm	-21.5	-18.5
-30 dBm	-31.5	-28.5
-40 dBm	-41.5	-38.5
-50 dBm	-51.5	-48.5
-60 dBm	-61.5	-58.5
-70 dBm	-71.5	-68.5
-80 dBm	-81.5	-78.5
-90 dBm	-91.5	-88.5
-100 dBm	-101.5	-98.5
-110 dBm	-111.5	-108.5

(11) Press TI pushbuttons as listed in (a) through (e) below:

- (a) **FUNCTION-CARR FREQ.**
- (b) **DATA ENTRY-1300 MHz.**

**TB 9-6625-2330-35**

- (c) **FUNCTION-CARR LEVEL.**
- (d) **DATA ENTRY- 13 dBm.**
- (e) **FUNCTION-RF ON** to on (red light lit).

(12) Using RF power measurement techniques, measuring receiver will indicate within limits specified in table 7 for TI RF power level setting.

(13) Press TI **FUNCTION-CARR LEVEL** and **DATA ENTRY** keys to set TI output level to next value listed in table 7. Measuring receiver will indicate within limits specified in table 7.

(14) Repeat (13) above for remaining levels listed in table 7.

Table 7. 1300 MHz RF Output

Test instrument <b>DATA ENTRY</b> level	Measuring receiver indications (dB)	
	Min	Max
13 dBm	10.5	15.5
10 dBm	7.5	12.5
5 dBm	2.5	7.5
0 dBm	-2.5	2.5

(15) Press TI **FUNCTION-CARR LEVEL** and **DATA ENTRY** keys to set TI output level to first value listed in table 8.

(16) Using standard tuned level measurement techniques, measuring receiver will indicate within limits specified in table 8 for TI RF level setting.

(17) Press TI **FUNCTION-CARR LEVEL** and **DATA ENTRY** keys to set TI output level to next value listed in table 8. Measuring receiver will indicate within limits listed in table 8.

(18) Repeat (17) above for remaining levels listed in table 8.

Table 8. 1300 MHz RF Output

Test instrument <b>DATA ENTRY</b> level	Measuring receiver indications (dB)	
	Min	Max
0 dBm	-2.5	2.5
-10 dBm	-12.5	-7.5
-20 dBm	-22.5	-17.5
-30 dBm	-32.5	-27.5
-40 dBm	-42.5	-37.5



Table 8. 1300 MHz RF Output - Continued

Test instrument <b>DATA ENTRY</b> level	Measuring receiver indications (dB)	
	Min	Max
-50 dBm	-52.5	-47.5
-60 dBm	-62.5	-57.5
-70 dBm	-72.5	-67.5
-80 dBm	-82.5	-77.5
-90 dBm	-92.5	-87.5
-100 dBm	-102.5	-97.5
-110 dBm	-112.5	-107.5

(19) Press TI **FUNCTION-RF ON** pushbutton to off (red light extinguished).

**b. Adjustments.** No adjustments can be made.

**11. Output Level Flatness**

**a. Performance Check**

**NOTE**

If necessary, perform measuring receiver and sensor module **ZERO** and **CALIBRATE**.

(1) Connect measuring receiver sensor module (11722A) to TI **RF OUTPUT**.

(2) Press TI pushbuttons as listed in (a) through (d) below:

(a) **FUNCTION-CARR FREQ** and **DATA ENTRY** keys to first TI frequency listed in table 9.

(b) **FUNCTION-CARR LEVEL**.

(c) **DATA ENTRY- 13 dBm**.

(d) **FUNCTION-RF ON** to on (red light lit).

**NOTE**

Ensure TI **REF IN/OUT** (rear panel) is still connected to measuring receiver **TIME BASE 10 MHz INPUT** (rear panel).

(3) Manually tune measuring receiver to first TI frequency listed in table 9.

(4) Set measuring receiver to measure RF power in **LOG** mode. Using measuring receiver and RF power measurement techniques, measuring receiver will indicate within limits specified in table 9.

(5) Repeat (2) (a), (3), and (4) above for remaining frequencies listed in table 9.

Table 9. Output Level Flatness

Test instrument <b>DATA ENTRY</b> frequency	Measuring receiver indications (dB)	
	Min	Max
.200 MHz	11.5	14.5
.500 MHz	11.5	14.5
1 MHz	11.5	14.5
3 MHz	11.5	14.5
10 MHz	11.5	14.5
30 MHz	11.5	14.5
100 MHz	11.5	14.5
200 MHz	11.5	14.5
300 MHz	11.5	14.5
400 MHz	11.5	14.5
500 MHz	11.5	14.5
600 MHz	11.5	14.5
700 MHz	11.5	14.5
800 MHz	11.5	14.5
900 MHz	11.5	14.5
1000 MHz	10.5	15.5
1100 MHz	10.5	15.5
1200 MHz	10.5	15.5
1300 MHz	10.5	15.5
1400 MHz	10.5	15.5
1500 MHz	10.5	15.5
1600 MHz	10.5	15.5
1700 MHz	10.5	15.5
1800 MHz	10.5	15.5
1900 MHz	10.5	15.5
2000 MHz	10.5	15.5

(6) Press TI **FUNCTION-RF ON** pushbutton to off (red light extinguished).

**b. Adjustments.** No adjustments can be made.

**12. Attenuation**

**a. Performance Check**

**NOTE**

If necessary, perform measuring receiver and sensor module **ZERO** and **CALIBRATE**.

(1) Connect measuring receiver sensor module (11722A) to TI **RF OUTPUT**.

**NOTE**

Ensure TI **REF IN/OUT** (rear panel) is still connected to measuring receiver **TIME BASE 10 MHz INPUT** (rear panel).

- (2) Press TI pushbuttons as listed in (a) through (e) below:
  - (a) **FUNCTION-CARR FREQ.**
  - (b) **DATA ENTRY- 500 MHz.**
  - (c) **FUNCTION-CARR LEVEL.**
  - (d) **DATA ENTRY- 0 dBm.**
  - (e) **FUNCTION-RF ON** to on (red light lit).
- (3) Using measuring receiver and RF power measurement techniques, measured power will indicate within limits specified in table 10 for 0 dBm.
- (4) Set measurement receiver to reference mode.
- (5) Set TI to next power level indicated in table 10.
- (6) Using standard tuned level measurement techniques, measuring receiver will indicate within limits specified for TI output level in table 10.
- (7) Repeat (5) and (6) above for remaining output levels listed in table 10.

Table 10. 500 MHz Attenuation

Test instrument <b>DATA ENTRY</b> level	Measuring receiver indications (dB)	
	Min	Max
0 dBm	-1.5	1.5
-10 dBm	-11.5	-8.5
-20 dBm	-21.5	-18.5
-30 dBm	-31.5	-28.5
-40 dBm	-41.5	-38.5
-50 dBm	-51.5	-48.5
-60 dBm	-61.5	-58.5
-70 dBm	-71.5	-68.5
-80 dBm	-81.5	-78.5
-90 dBm	-91.5	-88.5
-100 dBm	-101.5	-98.5
-110 dBm	-111.5	-108.5

- (8) Press TI pushbuttons as listed in (a) through (e) below:
  - (a) **FUNCTION-CARR FREQ.**
  - (b) **DATA ENTRY-1300 MHz.**
  - (c) **FUNCTION-CARR LEVEL.**
  - (d) **DATA ENTRY- 0 dBm.**
  - (e) **FUNCTION-RF ON** to on (red light lit).
- (9) Using measuring receiver and RF power measurement techniques, measured power will indicate within limits specified in table 11 for 0 dBm.
- (10) Set measurement receiver to reference mode.
- (11) Set TI to next power level indicated in table 11.
- (12) Using standard tuned level measurement techniques, measuring receiver will indicate within limits specified for TI output level in table 11.

**TB 9-6625-2330-35**

(13) Repeat (11) and (12) above for remaining output levels listed in table 11.

Table 11. 1300 MHz Attenuation

Test instrument <b>DATA ENTRY</b> level	Measuring receiver indications (dB)	
	Min	Max
0 dBm	-2.5	2.5
-10 dBm	-12.5	-7.5
-20 dBm	-22.5	-17.5
-30 dBm	-32.5	-27.5
-40 dBm	-42.5	-37.5
-50 dBm	-52.5	-47.5
-60 dBm	-62.5	-57.5
-70 dBm	-72.5	-67.5
-80 dBm	-82.5	-77.5
-90 dBm	-92.5	-87.5
-100 dBm	-102.5	-97.5
-110 dBm	-112.5	-107.5

(14) Press TI **FUNCTION-RF ON** pushbutton to off (red light extinguished).

(15) Disconnect TI **EXT REF IN/OUT** (rear panel) from measuring receiver **TIME BASE 10 MHz INPUT** (rear panel).

**b. Adjustments.** No adjustments can be made.

**13. Spectral Purity**

**a. Performance Check**

- (1) Connect spectrum analyzer **INPUT 50 Ω** to TI **RF OUTPUT**.
- (2) Connect TI **REF IN/OUT** (rear panel) to spectrum analyzer **10 MHz REF IN** (rear panel).
- (3) Press TI pushbuttons as listed in (a) through (e) below:
  - (a) **FUNCTION-CARR FREQ.**
  - (b) **DATA ENTRY- .450 MHz.**
  - (c) **FUNCTION-CARR LEVEL.**
  - (d) **DATA ENTRY- 13 dBm.**
  - (e) **FUNCTION-RF ON** to on (red light lit).
- (4) Set spectrum analyzer controls as listed in (a) through (g) below:
  - (a) **Preset.**
  - (b) **AMPLITUDE, [Ref Level], 1, 3 [dBm].**
  - (c) **FREQUENCY, [Center Freq], 4, 5, 0, [kHz].**
  - (d) **BW/Avg, [Res BW], 1, 0, [kHz].**
  - (e) **[Video BW], (Auto).**

- (f) **SPAN, 1, [MHz].**
  - (g) **Marker, [Off].**
- (5) Allow display to sweep a few times then set spectrum analyzer controls as listed in (a) through (d).
- (a) **Peak Search.**
  - (b) **Marker→, [Mkr→CF].**
  - (c) **Marker, [Delta].**
  - (d) **FREQUENCY, [Center Freq], (harmonic frequency listed in table 12) [MHz].**
- (6) Spectrum analyzer **Mkr1** will indicate less than dBc limit listed in table 12.
- (7) Set TI frequency and spectrum analyzer center frequency to next frequency listed in table 12 and repeat (4) (g) through (6) above.
- (8) Repeat (7) above for remaining frequencies listed in table 12.

Table 12. Spectral Purity

Test instrument		Spectrum analyzer		
DATA ENTRY level (dBm)	DATA ENTRY frequency (MHz)	Harmonic frequency (MHz)	Harmonic number	dBc
13	.450	.900	2 <sup>d</sup>	<-25
13	.450	1.350	3 <sup>d</sup>	<-25
13	1	2	2 <sup>d</sup>	<-25
13	1	3	3 <sup>d</sup>	<-25
13	166.666665	333.333330	2 <sup>d</sup>	<-25
13	166.666665	499.999995	3 <sup>d</sup>	<-25
13	250	500	2 <sup>d</sup>	<-25
13	333.333335	666.666670	2 <sup>d</sup>	<-25
13	333.333335	1000.000005	3 <sup>d</sup>	<-25
13	500	1000	2 <sup>d</sup>	<-25
13	2000	1000	.5	<-20
13	2000	4000	2 <sup>d</sup>	<-25

- (9) Press TI pushbuttons as listed in (a) through (e) below:
- (a) **FUNCTION-CARR FREQ.**
  - (b) **DATA ENTRY- 100 MHz.**
  - (c) **FUNCTION-CARR LEVEL.**
  - (d) **DATA ENTRY- 7 dBm.**
  - (e) **FUNCTION-RF ON** to on (red light lit).
- (10) Set spectrum analyzer controls as listed in (a) through (g) below:
- (a) **Preset.**
  - (b) **FREQUENCY, [Center Freq], 1, 0, 1 MHz.**
  - (c) **AMPLITUDE, [Ref Level], 7, [dBm].**

**TB 9-6625-2330-35**

- (d) **BW/Avg, [Res BW], (Auto).**
- (e) **[Video BW], (Auto).**
- (f) **Marker, [Off].**
- (g) **SPAN, 2, ., 5 [kHz].**

- (11) Set spectrum analyzer to single sweep mode and take one sweep.
- (12) Set spectrum analyzer marker to normal.
- (13) Spectrum analyzer **Mkr1** will indicate less than dB limit listed in table 13.

Table 13. Noise Floor

Test Instrument		Spectrum Analyzer		
DATA ENTRY frequency	DATA ENTRY level	Center frequency	Span	dB indications
100 MHz	7 dBm	101 MHz	2.5 kHz	<-87 dBm

- (14) Press TI pushbuttons as listed in (a) through (d) below:
  - (a) **FUNCTION-CARR FREQ** to first TI frequency listed in table 14 below.
  - (b) **FUNCTION-CARR LEVEL.**
  - (c) **DATA ENTRY- 13 dBm.**
  - (d) **FUNCTION-RF ON** to on (red light lit).

(15) Using spectrum analyzer, verify that all non-harmonic spurious signals are less than dBc limit listed in table 14.

- (16) Repeat (14) and (15) for remaining frequencies listed in table 14.

Table 14. Spurious Signals

Test instrument		Spectrum analyzer
DATA ENTRY level (dBm)	DATA ENTRY frequency (MHz)	Spurious signal level
13	25 MHz	<-50 dBc
13	50 MHz	<-50 dBc
13	100 MHz	<-50 dBc
13	225 MHz	<-50 dBc
13	450 MHz	<-50 dBc
13	750 MHz	<-50 dBc
13	1500 MHz	<-50 dBc

**b. Adjustments.** No adjustments can be made.

**14. Pulse Modulation**

**a. Performance Check**

- (1) Connect equipment as shown in figure 1.
- (2) Press pulse generator pushbuttons for a pulse output as listed in (a) through (h) below:
  - (a) **CHANNEL A.**
  - (b) **Period** and enter **10m/kHz** from data keyboard.
  - (c) **Width** and enter **5 m/kHz** from data keyboard.

- (d) **Vhigh** and enter **5** from data keyboard.
- (e) **Vlow** and enter **0** from data keyboard.
- (f) **Delay** and enter **0 n/GHz** from data keyboard.
- (g) **2 Pulse** and enter **OFF Enter/Hz** from data keyboard.
- (h) On 9211 output module, disable (red light extinguished).

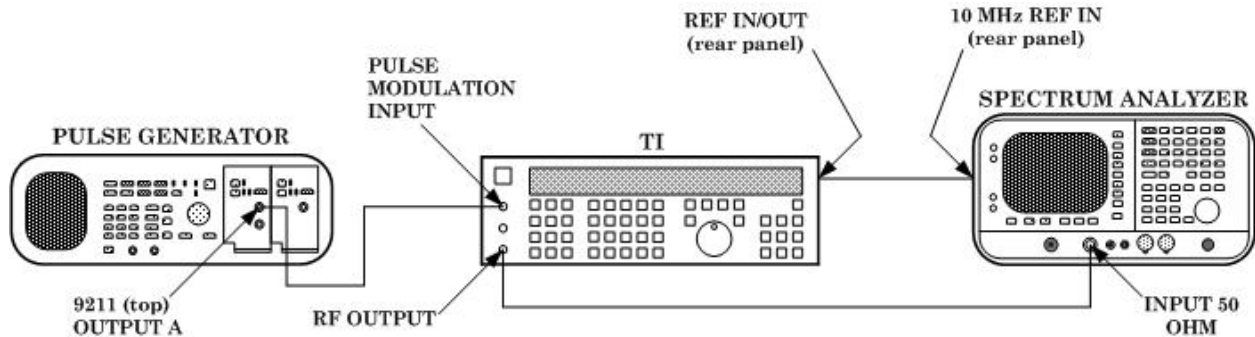

Figure 1. Pulse modulation on/off ratio hookup.

- (3) Press TI pushbuttons as listed in (a) through (e) below:
  - (a) **FUNCTION-CARR FREQ.**
  - (b) **DATA ENTRY- 1 GHz.**
  - (c) **FUNCTION-CARR LEVEL.**
  - (d) **DATA ENTRY- 10 dBm.**
  - (e) **FUNCTION-RF ON** to on (red light lit).
- (4) Press spectrum analyzer pushbuttons as listed in (a) through (d) below:
  - (a) **Preset.**
  - (b) **AMPLITUDE, [Ref Level], 1, 0, [dBm].**
  - (c) **FREQUENCY, [Center Freq], 1, [GHz].**
  - (d) **SPAN, 1, ., 5, [MHz].**
- (5) Press spectrum analyzer pushbuttons as listed in (a) through (j) below:
  - (a) **BW Avg, [Res BW], 1, 0, 0, [kHz].**
  - (b) **[Video BW], 1, [kHz].**
  - (c) **Marker.**
  - (d) **SPAN, 0, [Hz].**
  - (e) **Sweep, [Sweep Time], 3, 0, [ms].**
  - (f) **Trig [Video], 1, 0, [-dBm].**
  - (g) **Marker.**
  - (h) Using rotary knob, adjust marker to top of square wave.
  - (i) **Marker, [Delta].**

**TB 9-6625-2330-35**

(j) Using rotary knob, adjust delta marker to bottom of square wave.

(6) Using spectrum analyzer, measure top to bottom of square wave in dB. Pulse envelope on/off ratio will indicate within limits specified in table 15.

Table 15. Pulse Modulation

Spectrum analyzer >dB
60

(7) Set TI **FUNCTION-RF ON** to off (red light extinguished).

(8) Connect equipment as shown in figure 2.

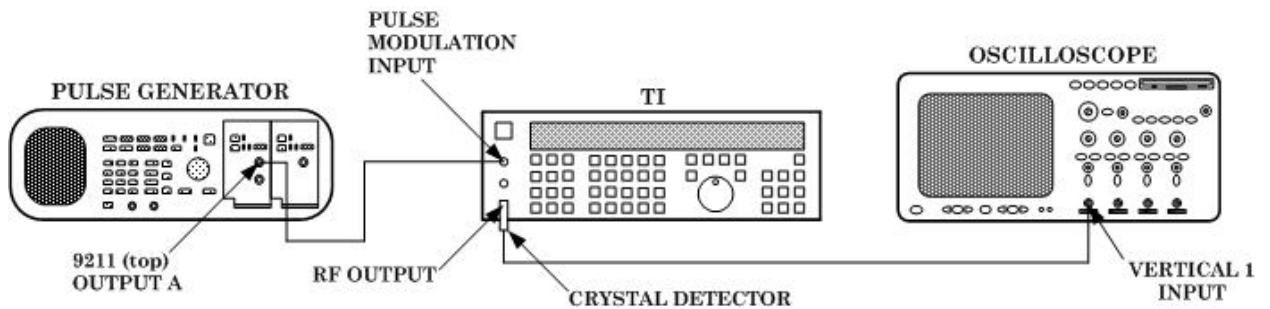

Figure 2. Pulse modulation risetime hookup.

(9) Adjust pulse generator output for a period of 20  $\mu$ s and a pulse width of 15  $\mu$ s.

(10) Set TI **FUNCTION-RF ON** to on (red light lit).

(11) Set oscilloscope input impedance to 50  $\Omega$ .

(12) Using oscilloscope measurement techniques, verify risetime of displayed envelope is within limits listed in table 16.

Table 16. Risetime

Oscilloscope < ns
25

(13) Using oscilloscope measurement techniques, verify falltime of displayed envelope is within limits listed in table 17.

Table 17. Falltime

Oscilloscope < ns
25

(14) Set TI **FUNCTION-RF ON** to off (red light extinguished).



**b. Adjustments.** No adjustments can be made.

**15. Internal Oscillator**

**a. Performance Check**

- (1) Connect TI **MODULATION IN/OUT** to audio analyzer **INPUT HIGH**.
- (2) Press TI pushbuttons as listed in (a) through (e) below:
  - (a) **FUNCTION-RF ON** to off (red light extinguished).
  - (b) **MODULATION/AUX-MOD SOURCE DISP** to **SOURCE ONE**.
  - (c) **FUNCTION-MOD FREQ**.
  - (d) **DATA ENTRY- 1 kHz**
  - (e) **MODULATION/AUX-MOD ON ONE** (red light lit).
- (3) Set audio analyzer to measure distortion. Audio analyzer distortion indication will be within limits specified in table 18.

Table 18. Internal Oscillator Distortion

Test instrument <b>MOD FREQ</b> frequency	Audio analyzer distortion indications (%)
1 kHz	< 0.2

- (4) Disconnect TI **MODULATION IN/OUT** from audio analyzer **INPUT HIGH**.
- (5) Connect TI **MODULATION IN/OUT** to audio analyzer **INPUT HIGH** using 50 Ω feedthrough termination.
- (6) Set audio analyzer to measure level. Audio analyzer indication will be within limits specified in table 19.

Table 19. Internal Oscillator Output Voltage

Test instrument <b>DATA ENTRY</b> mod frequency setting	Audio analyzer level indication (V rms)	
	Min	Max
1 kHz	0.950	1.050

- (7) Disconnect TI **MODULATION IN/OUT** from audio analyzer **INPUT HIGH**.
- (8) Connect TI **MODULATION IN/OUT** to frequency counter **A** input.
- (9) Set up frequency counter controls to measure frequency with 50 Ω input.
- (10) Set TI **FUNCTION-MOD FREQ** and **DATA ENTRY** keys to first frequency listed in table 20.
- (11) Frequency counter indication will be within limits specified for frequency listed in table 20.

**TB 9-6625-2330-35**

(12) Set TI **FUNCTION-MOD FREQ** and **DATA ENTRY** keys to next frequency listed in table 20.

(13) Frequency counter indication will be within limits specified in table 20 for frequency setting of TI.

(14) Repeat (12) and (13) above for remaining frequencies listed in table 20.

Table 20. Internal Oscillator Frequency

Test instrument <b>DATA ENTRY</b> mod frequency settings	Frequency counter indications (Hz)	
	Min	Max
1 kHz	.999 k	1.001 k
.100 kHz	.099 k	.101 k
.500 kHz	.499 k	.501 k
5 kHz	4.999 k	5.001 k
10 kHz	9.999 k	10.001 k
50 kHz	49.999 k	50.001 k
100 kHz	99.999 k	100.001 k
200 kHz	199999	200001
300 kHz	299999	300001
400 kHz	399999	400001
500 kHz	499999	500001

(15) Disconnect **TI MODULATION IN/OUT** from frequency counter **A** input.

**b. Adjustments.** No adjustments can be made.

**16. Amplitude Modulation**

**a. Performance Check**

(1) Connect equipment as shown in figure 3.

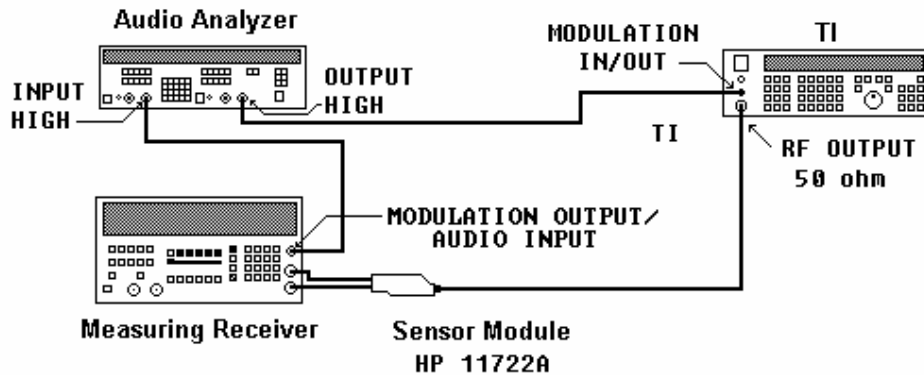

Figure 3. AM modulation hookup.

- (2) Press TI pushbuttons as listed in (a) through (j) below:
- (a) **FUNCTION-CARR FREQ.**
  - (b) **DATA ENTRY- 500 MHz.**
  - (c) **FUNCTION-CARR LEVEL.**
  - (d) **DATA ENTRY- 0 dBm.**
  - (e) **FUNCTION- RF ON** to on (red light lit).
  - (f) **FUNCTION-MOD FREQ.**
  - (g) **DATA ENTRY- 1 kHz.**
  - (h) **FUNCTION-MOD LEVEL.**
  - (i) **DATA ENTRY- 30% AM.**
  - (j) **MODULATION/AUX –MOD ON ONE** to on (red light lit).
- (3) Set measuring receiver to measure FM with a 3 kHz low-pass filter and a 300 Hz high-pass filter.
- (4) Measuring receiver will indicate within limits specified in table 21.

Table 21. Incidental FM

Carrier frequency	<b>MOD FREQ</b>	Modulation %	Measuring receiver <Hz
1 GHz	1 kHz	30	200

- (5) Set measuring receiver to measure AM with 15 kHz low-pass filter and a 300 Hz high-pass filter.
- (6) Set audio analyzer to measure distortion.
- (7) Press TI **FUNCTION-MOD LEVEL** and **DATA ENTRY** keys for values listed in table 22. Using measuring receiver, measure AM percent of modulation. Measuring receiver will indicate within limits specified in table 22.

Table 22. Internal AM Modulation Accuracy

Test instrument <b>DATA ENTRY</b> percent of modulation	Measuring receiver modulation indications (%)	
	Min	Max
30%	23	37
60%	53	67
90%	83	97

- (8) Press TI **FUNCTION-MOD LEVEL** and **DATA ENTRY** keys for values listed in table 23. Using audio analyzer, measure AM distortion. Audio analyzer will indicate within limits specified in table 23.

Table 23. Internal AM Modulation Distortion

Test instrument <b>DATA ENTRY</b> percent of modulation	Audio analyzer distortion indications (<%)
30%	3
60%	3
90%	3

**TB 9-6625-2330-35**

- (9) Set measuring receiver to measure AM with all filters off.
- (10) Press TI **MODULATION/AUX –MOD ON ONE** to off (red light extinguished).
- (11) Press TI **MODULATION/AUX-MOD SOURCE DISP** to **EXTERNAL** and **MODULATION/AUX-MOD ON EXT** to on (red light lit) keys.
- (12) Press TI **FUNCTION-MOD LEVEL** and **DATA ENTRY- 90% AM** keys.
- (13) Set audio analyzer to output a 1 kHz signal at 1.414 V rms with an output impedance of 600 Ω.
- (14) Set audio analyzer to measure level and set units to dB, then set audio analyzer to ratio mode.
- (15) Set audio analyzer to output frequencies listed in table 24 and verify audio analyzer level indication is within limits specified in table 24.

Table 24. External AM Frequency Response

Test description	Audio analyzer frequency (Hz)	Audio analyzer indication	
		Min	Max
250 Hz Response	250	-1	1
400 Hz Response	400	-1	1
500 Hz Response	500	-1	1
2 kHz Response	2000	-1	1
5 kHz Response	5000	-1	1
10 kHz Response	10000	-1	1

**b. Adjustments.** No adjustments can be made.

**17. Frequency Modulation**

**a. Performance Check**

- (1) Connect equipment as shown in figure 4.

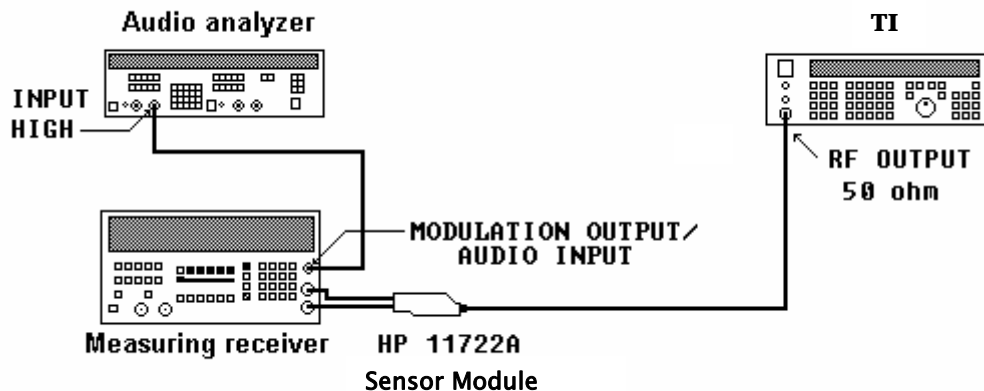

Figure 4. FM modulation hookup.

- (2) Press TI pushbuttons as listed in (a) through (i) below:

- (a) **FUNCTION-CARR FREQ.**
- (b) **DATA ENTRY- 1 GHz.**
- (c) **FUNCTION-CARR LEVEL.**
- (d) **DATA ENTRY- 13 dBm.**
- (e) **FUNCTION-RF ON** to on (red light lit).
- (f) **MODULATION/AUX-MOD SOURCE DISP** to **SOURCE ONE.**
- (g) **MODULATION/AUX- MOD ON ONE** to off (red light extinguished).
- (h) **MODULATION/AUX- MOD ON EXT** to off (red light extinguished).
- (i) **MODULATION/AUX- MOD OFF** (red light lit).

(3) Set measuring receiver to measure FM with an RMS detector, 3 kHz low-pass filter, and a 300 Hz high-pass filter.

(4) Measuring receiver will indicate within limits specified in table 25.

Table 25. Residual Response

Measuring receiver indication (Hz)
<20

(5) Press TI pushbuttons as listed in (a) through (k) below:

- (a) **FUNCTION-CARR FREQ.**
- (b) **DATA ENTRY- 1 GHz.**
- (c) **FUNCTION-CARR LEVEL.**
- (d) **DATA ENTRY- 13 dBm.**
- (e) **FUNCTION- MOD LEVEL.**
- (f) **DATA ENTRY- 20 kHz.**
- (g) **FUNCTION- MOD FREQ.**
- (h) **DATA ENTRY- 1 kHz.**
- (i) **MODULATION/AUX-MOD ON ONE** to on (red light lit).
- (j) **MODULATION/AUX- MOD OFF** (red light extinguished).
- (k) **FUNCTION-RF ON** to on (red light lit).

(6) Set measuring receiver to measure AM with a + PEAK detector, 3 kHz low-pass filter and a 300 Hz high-pass filter.

(7) Measuring receiver will indicate within limits specified in table 26.

Table 26. Incidental AM

Measuring receiver indication (%)
<1

(8) Press TI pushbuttons as listed in (a) through (f) below:

- (a) **FUNCTION-CARR FREQ.**
- (b) **DATA ENTRY – 250 MHz.**
- (c) **FUNCTION-CARR LEVEL.**
- (d) **DATA ENTRY – 10 dBm.**
- (e) **FUNCTION – MOD LEVEL.**

**TB 9-6625-2330-35**

(f) **DATA ENTRY – 200 kHz.**

(9) Set up measuring receiver to measure FM with a + PEAK detector, no high-pass filter and no low-pass filter.

(10) Set up audio analyzer to measure distortion with a slow detecting noise rejecting filter.

(11) Audio analyzer will indicate within limits specified in table 27.

Table 27. FM Audio Distortion

Audio analyzer distortion indication (%)
2%

(12) Press **TI FUNCTION-CARR FREQ**, **FUNCTION-MOD LEVEL**, and **DATA ENTRY** keys for values listed in table 28. Using measuring receiver, measure FM deviation. Measuring receiver will indicate within limits specified in table 28.

Table 28. FM Deviation

Test instrument			Measuring receiver indications (kHz)	
<b>DATA ENTRY</b> carrier frequency (MHz)	<b>DATA ENTRY</b> modulation frequency (kHz)	<b>DATA ENTRY</b> frequency deviation (kHz)	Min	Max
1050	1	100	90	110
256	1	25	22.5	27.5
50	1	150	135	165
256	1	187	168.3	205.7

**b. Adjustments.** No adjustments can be made.

**18. Phase Modulation**

**a. Performance Check**

(1) Connect measuring receiver sensor module to **TI RF OUTPUT**.

(2) Press TI pushbuttons as listed in (a) through (j) below:

- (a) **FUNCTION-CARR FREQ.**
- (b) **DATA ENTRY- 8 MHz.**
- (c) **FUNCTION-CARR LEVEL.**
- (d) **DATA ENTRY- 10 dBm.**
- (e) **FUNCTION-MOD FREQ.**
- (f) **DATA ENTRY- 1 kHz.**
- (g) **FUNCTION-MOD LEVEL.**
- (h) **DATA ENTRY- 10 RAD.**
- (i) **MODULATION/AUX-MOD ON ONE** (red light lit).
- (j) **FUNCTION-RF ON to on** (red light lit).

(3) Set measuring receiver to measure PM with a + PEAK detector, 15 kHz low-pass filter and a 300 Hz high-pass filter.

(4) Using measuring receiver, measure phase modulation. Measuring receiver phase modulation indication will be within limits specified for first carrier frequency listed in table 29.

(5) Set TI **FUNCTION-CARR FREQ** and **DATA ENTRY** keys to next frequency listed in table 29.

(6) Measuring receiver phase modulation indication will be within limits specified in table 30 for carrier frequency setting of TI.

(7) Repeat (5) and (6) above for remaining frequency listed in table 29.

Table 29. Phase Modulation

Test instrument Carrier frequency (MHz)	Measuring receiver phase modulation indications (rad)	
	Min	Max
8	9	11
1050	9	11
.50	9	11

(8) Press TI pushbuttons as listed in (a) through (j) below:

- (a) **FUNCTION-CARR FREQ.**
- (b) **DATA ENTRY- 8 MHz.**
- (c) **FUNCTION- CARR LEVEL.**
- (d) **DATA ENTRY- 10 dBm.**
- (e) **FUNCTION-MOD FREQ.**
- (f) **DATA ENTRY- 1 kHz.**
- (g) **FUNCTION-MOD LEVEL.**
- (h) **DATA ENTRY- 10 RAD.**
- (i) **MODULATION/AUX-MOD ON ONE** (red light lit).
- (j) **FUNCTION-RF ON** to on (red light lit).

(9) Set measuring receiver to measure 1 kHz audio distortion.

(10) Using measuring receiver, measure audio distortion. Measuring receiver audio distortion indication will be within limits specified for first carrier frequency listed in table 30.

(11) Set TI **FUNCTION-CARR FREQ** and **DATA ENTRY** keys to next frequency listed in table 30.

(12) Measuring receiver audio distortion indication will be within limits specified in table 31 for carrier frequency setting of TI.

(13) Repeat (11) and (12) above for remaining frequency listed in table 30.

**TB 9-6625-2330-35**

Table 30. Phase Modulation Audio Distortion

Test instrument carrier frequency (MHz)	Measuring receiver audio distortion indications (%)
8	2
1050	2
.50	2

**b. Adjustments.** No adjustments can be made.

**19. Final Procedure**

**a.** Deenergize and disconnect all equipment.

**b.** Annotate and affix DA label/form in accordance with TB 750-25.



By Order of the Secretary of the Army:

Official:

**PETER J. SCHOOMAKER**  
*General, United States Army*  
*Chief of Staff*



*Joel B. Hudson*

**JOEL B. HUDSON**  
*Administrative Assistant to the*  
*Secretary of the*  
*Army*

0404904

Distribution:

To be distributed in accordance with the initial distribution number (IDN) 344734, requirements for calibration procedure TB 9-6625-2330-35.



### Instructions for Submitting an Electronic 2028

The following format must be used if submitting an electronic 2028. The subject line must be exactly the same and all fields must be included; however, only the following fields are mandatory: 1, 3, 4, 5, 6, 7, 8, 9, 10, 13, 15, 16, 17, and 27.

From: "Whomever" [whomever@redstone.army.mil](mailto:whomever@redstone.army.mil)

To: <2028@redstone.army.mil

Subject: DA Form 2028

1. **From:** Joe Smith
2. **Unit:** home
3. **Address:** 4300 Park
4. **City:** Hometown
5. **St:** MO
6. **Zip:** 77777
7. **Date Sent:** 19-OCT-93
8. **Pub no:** 55-2840-229-23
9. **Pub Title:** TM
10. **Publication Date:** 04-JUL-85
11. **Change Number:** 7
12. **Submitter Rank:** MSG
13. **Submitter FName:** Joe
14. **Submitter MName:** T
15. **Submitter LName:** Smith
16. **Submitter Phone:** 123-123-1234
17. **Problem:** 1
18. **Page:** 2
19. **Paragraph:** 3
20. **Line:** 4
21. **NSN:** 5
22. **Reference:** 6
23. **Figure:** 7
24. **Table:** 8
25. **Item:** 9
26. **Total:** 123
27. **Text**

This is the text for the problem below line 27.





